





Fuel Tank Draining

Special Tool(s)

 <p>ST2134-A</p>	<p>Fuel Draining Hose 310-102</p>
 <p>ST1134A</p>	<p>Fuel Storage Tanker 164-R3202 or equivalent</p>
 <p>ST1839-A</p>	<p>Socket, Fuel Tank Sender Unit 310-D006 (D90P-9275-A) or equivalent</p>

Material

Item	Specification
<p>Motorcraft® SAE 5W-20 Premium Synthetic Blend Motor Oil XO-5W20-QSP (US); Motorcraft® SAE 5W-20 Super Premium Motor Oil CXO-5W20-LSP12 (Canada); or equivalent</p>	<p>WSS-M2C930-A</p>

 **WARNING:** Do not smoke, carry lighted tobacco or have an open flame of any type when working on or near any fuel-related component. Highly flammable mixtures are always present and may be ignited. Failure to follow these instructions may result in serious personal injury.

 **WARNING:** Do not carry personal electronic devices such as cell phones, pagers or audio equipment of any type when working on or near any fuel-related component. Highly flammable mixtures are always present and may be ignited. Failure to follow these instructions may result in serious personal injury.

 **WARNING:** When handling fuel, always observe fuel handling precautions and be prepared in the event of fuel spillage. Spilled fuel may be ignited by hot vehicle components or other ignition sources. Failure to follow these instructions may result in serious personal injury.

 **WARNING:** Always disconnect the battery ground cable at the battery when working on an evaporative emission (EVAP) system or fuel-related component. Highly flammable mixtures are always present and may be ignited. Failure to follow these instructions may result in serious personal injury.

 **WARNING:** Before working on or disconnecting any of the fuel tubes or fuel system components,

relieve the fuel system pressure to prevent accidental spraying of fuel. Fuel in the fuel system remains under high pressure, even when the engine is not running. Failure to follow this instruction may result in serious personal injury.



WARNING: Remove the fuel filler cap slowly. The fuel system may be under pressure. If the fuel filler cap is venting vapor or if you hear a hissing sound, wait until it stops before completely removing the fuel filler cap. Otherwise, fuel may spray out. Failure to follow these instructions may result in serious personal injury.

1. Release the fuel system pressure. For additional information, refer to [Fuel System Pressure Release](#) in this section.
2. Disconnect the battery ground cable. For additional information, refer to [Section 414-01](#).
3. Carefully turn the fuel tank filler cap counterclockwise approximately one-fourth turn until the thread disengages and position aside.
4. **NOTICE:** When removing the Fuel Draining Hose, the fitting on the end of the hose can become detained by the safety valve. Carefully remove the hose using a gentle agitating motion to avoid detaching the hose from the fitting.

NOTE: The Fuel Draining Hose must be inserted into the fuel tank filler pipe until the fitting on the end of the hose enters into the fuel tank, opening the safety valve.

Insert the Fuel Draining Hose into the fuel tank filler pipe.

5. **NOTE:** This step will remove approximately one-eighth tank of fuel from a completely full fuel tank and the majority of any residual fuel from the fuel tank filler pipe. Also the fuel in the fuel tank will be below the Fuel Pump (FP) module mounting flange for [FP](#) module removal without fuel spillage.

Attach the Fuel Storage Tanker to the Fuel Draining Hose and remove approximately one-eighth tank of fuel (from a completely full tank), lowering the fuel level below the [FP](#) module mounting flange.

6. Remove the rear seat cushion. For additional information, refer to [Section 501-10](#).
7. Remove the [FP](#) module and fuel level sensor access covers and position aside.

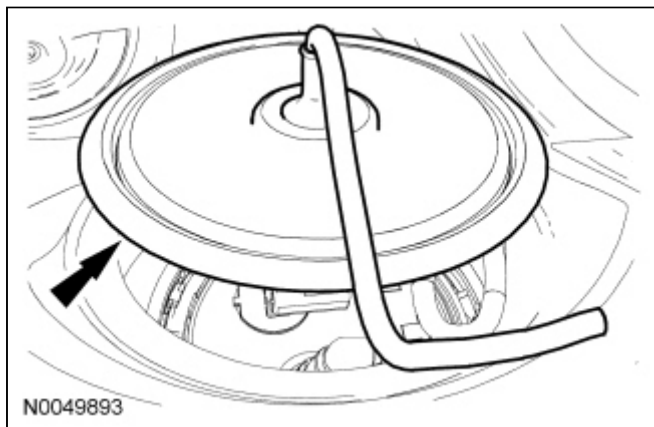

8. **NOTE:** Clean the [FP](#) module connections, couplings, flange surfaces and the immediate surrounding area of any dirt or foreign material.

Disconnect the [FP](#) module electrical connector.

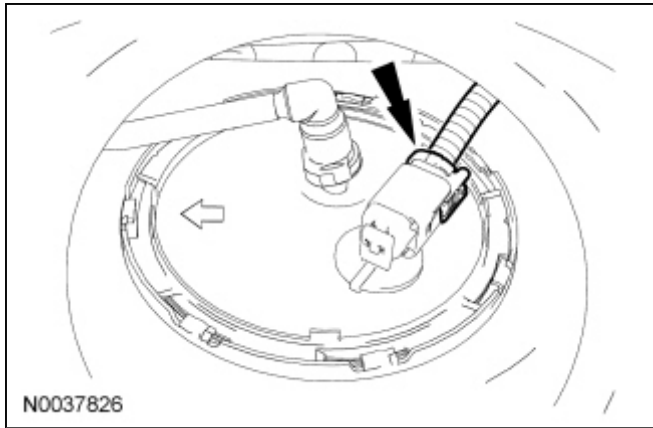

9. **NOTE:** Place absorbent pads in the general work area in case of fuel spillage.

Disconnect the rear fuel tube-to- **FP** module quick connect coupling. For additional information, refer to [Section 310-00](#).

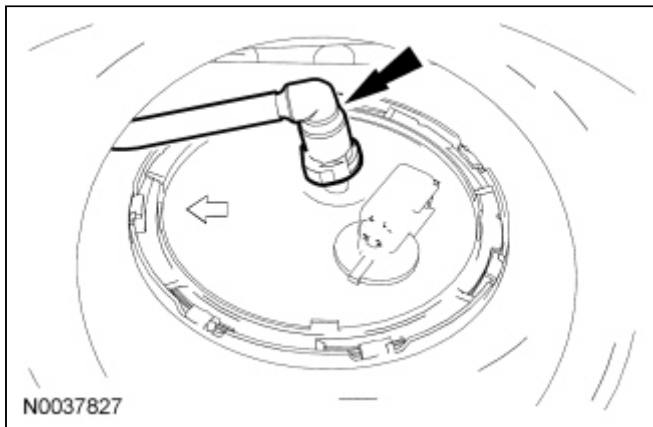

10. **NOTICE:** Carefully install the Fuel Tank Sender Unit Socket to avoid damage to the Fuel Pump (FP) module when removing the lock ring.

NOTE: When installing the **FP** module, install a new lock ring and O-ring seal.

Install the Fuel Tank Sender Unit Socket and remove the **FP** module lock ring.

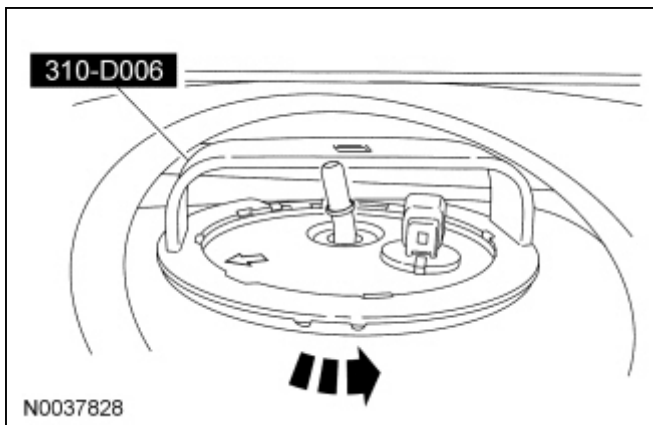

11. **NOTICE:** The Fuel Pump (FP) module must be handled carefully to avoid damage to the float arm.

Position the **FP** module aside. Using the Fuel Storage Tanker, completely drain the remaining fuel from the LH saddle of the fuel tank.

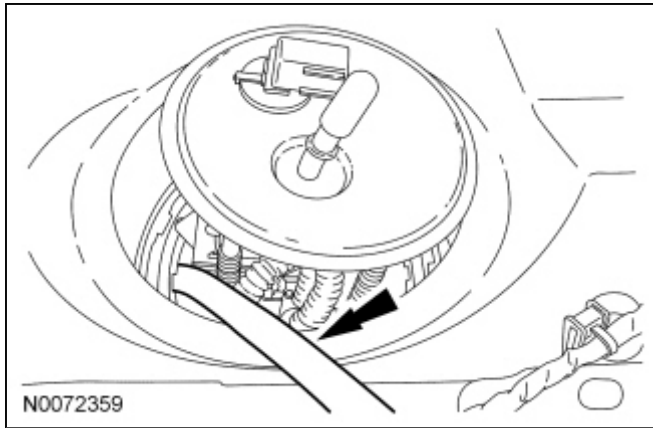

12. **NOTE:** Inspect the surfaces of the **FP** module flange and fuel tank O-ring seal contact surfaces. Do not polish or adjust the O-ring seal contact area of the fuel tank flange or the fuel tank. Install a new **FP** module or fuel tank if the O-ring seal contact area is bent, scratched or corroded.

NOTE: To install, apply clean engine oil to the O-ring seal.

Remove and discard the **FP** module O-ring seal.

13. **NOTE:** Clean the fuel level sensor connections, flange surfaces and the immediate surrounding area of any dirt or foreign material.

Disconnect the fuel level sensor electrical connector.

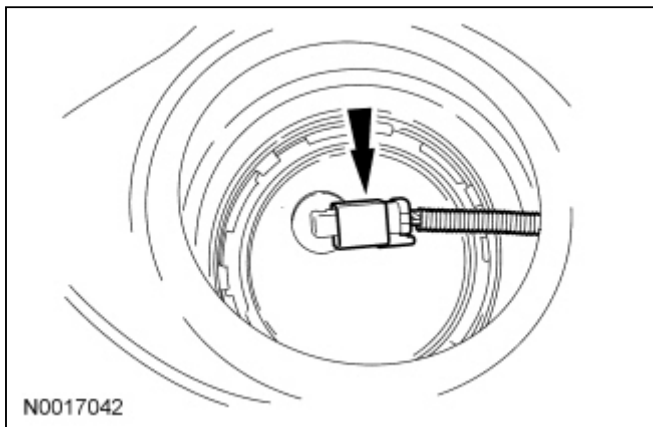

14. **NOTICE:** Carefully install the Fuel Tank Sender Unit Socket to avoid damage to the fuel level sensor when removing the lock ring.

NOTE: When installing the fuel level sensor, install a new lock ring and O-ring seal.

Install the Fuel Tank Sender Unit Socket and remove the fuel level sensor lock ring.

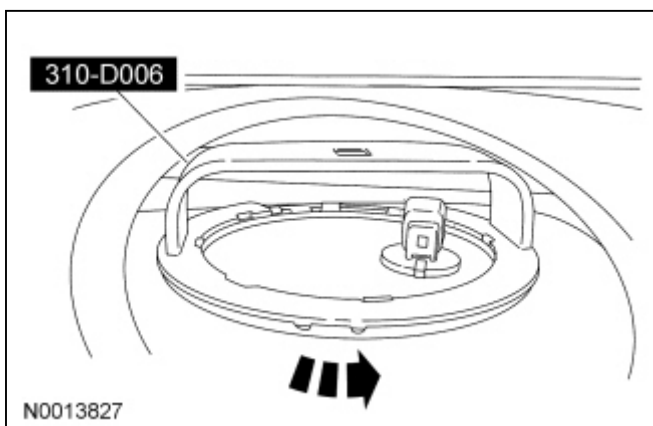

15. **NOTICE:** The fuel level sensor must be handled carefully to avoid damage to the float arm.

Position the fuel level sensor aside. Using the Fuel Storage Tanker, completely drain the RH saddle of the fuel tank.

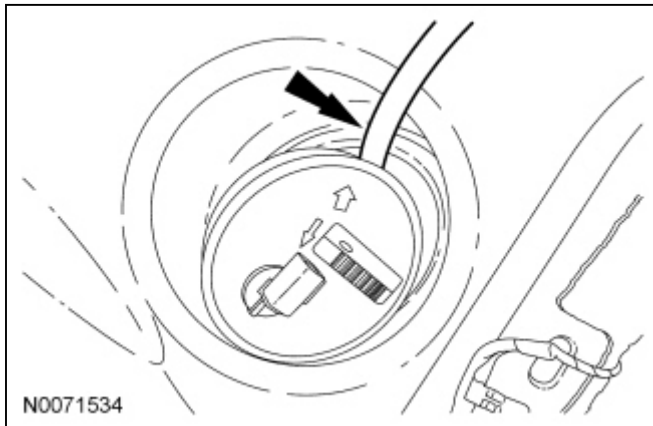

16. **NOTE:** Inspect the surfaces of the fuel level sensor flange and fuel tank O-ring seal contact surfaces. Do not polish or adjust the O-ring seal contact area of the fuel tank flange or the fuel tank. Install a new fuel level sensor or fuel tank if the O-ring seal contact area is bent, scratched or corroded.

NOTE: To install, apply clean engine oil to the O-ring seal.

Remove and discard the fuel level sensor O-ring seal.
